

dodson[®]

INSTALLATION INSTRUCTIONS

DQ381 STREET PLUS CLUTCH

DMS-00-0084 REV 001

28 DECEMBER 2023

**PREPARED BY: JAN PISL
DATE: 13DEC2023**

**RELEASED BY: 
DATE: 28DEC2023**

REVISION UPDATE NOTES:

The following table indicates the changes we have made in either the disassembly or assembly of the product you have received. All changes are indicated by a revision bar in the margin.

If you have any questions email us at technical@dodsonmotorsport.com

Revision	Date	Description
REV.001	28DEC2023	- Initial release.

READ FIRST

For best results, we recommend only using **Manual (M)** or **Sport (S)** transmission modes.

We have seen great results when using our clutch kits with a suitable transmission tune, however it is not necessary to be used with the Dodson Street Plus range.

This kit requires the reuse of the OE circlips and the small clutch top plate.

DQ381 STREET PLUS CLUTCH KIT CONTENTS (DMS-8573)

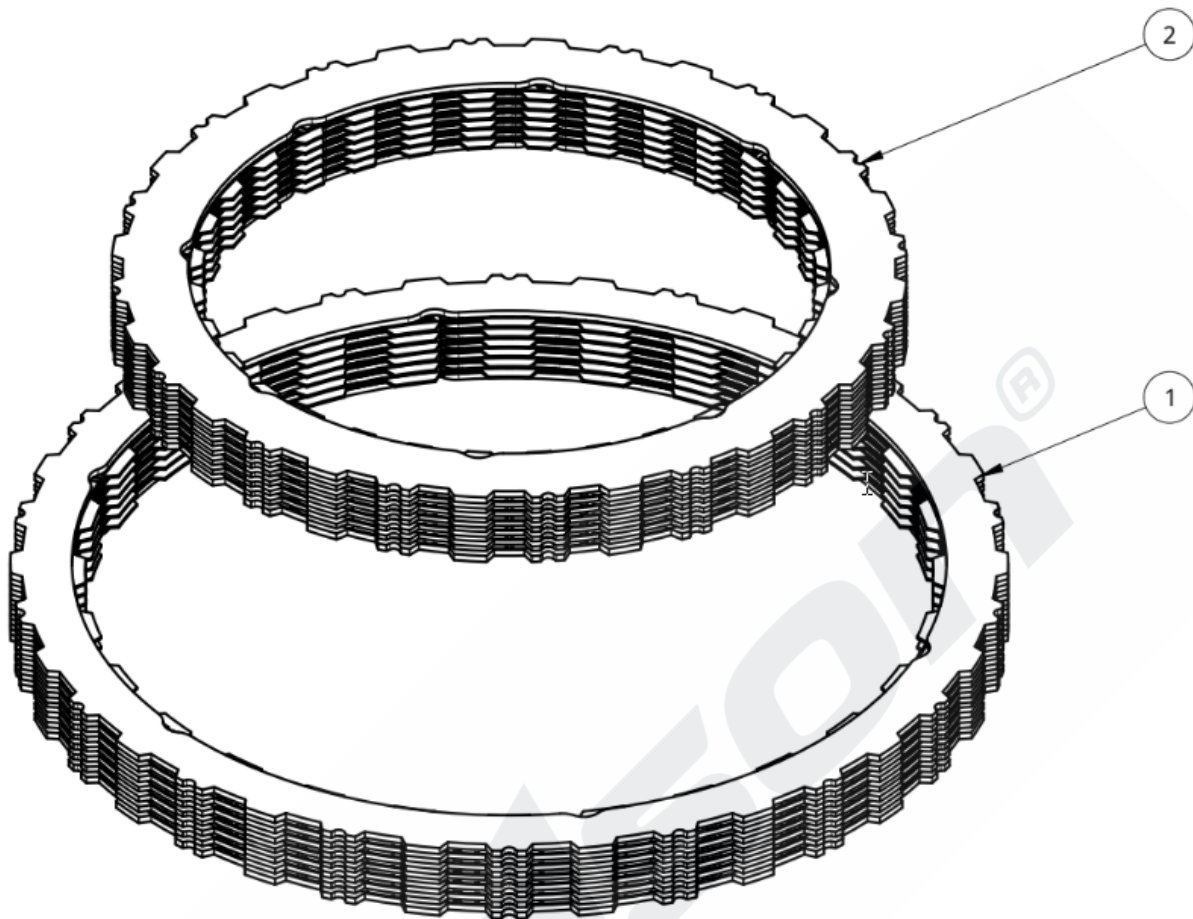

Item Number	Part Name	DMS Code	Qty
1	Large Clutch Stack	DMS-8575	1
2	Small Clutch Stack	DMS-8574	1

BY OPENING AND USING THIS DOCUMENT YOU AGREE TO ABIDE BY THE FOLLOWING CONDITIONS. INFORMATION CONTAINED IN PART OR IN WHOLE REMAINS WITH DODSON MOTORSPORT. DODSON MOTORSPORT ACCEPTS NO RESPONSIBILITY FOR ANY REASON WHATSOEVER. DO NOT COPY / REPRODUCE IN ANY FORM OR MAKE PUBLIC WITHOUT THE PERMISSION OF DODSON MOTORSPORT.

DQ381 STREET PLUS KIT INSTALLATION INSTRUCTIONS DISASSEMBLY

STEP 1

Remove the clutch cover retaining circlip and the cover itself, **taking care not to damage the seal in the center of the cover.**

To remove the clutch from the transmission you must remove the large circlip retaining the lid. You must then remove the lid and small circlip holding the large basket. **We recommend marking the lid to keep it in the same position during reassembly.**



STEP 2

Pull the clutch unit out of the transmission.



BY OPENING AND USING THIS DOCUMENT YOU AGREE TO ABIDE BY THE FOLLOWING CONDITIONS. INFORMATION CONTAINED IN PART OR IN WHOLE REMAINS WITH DODSON MOTORSPORT. DODSON MOTORSPORT ACCEPTS NO RESPONSIBILITY FOR ANY REASON WHATSOEVER. DO NOT COPY / REPRODUCE IN ANY FORM OR MAKE PUBLIC WITHOUT THE PERMISSION OF DODSON MOTORSPORT.

STEP 3

Remove both clutch baskets.



STEP 4

Remove the **small clutch circlip** using a small screwdriver or a pick.



BY OPENING AND USING THIS DOCUMENT YOU AGREE TO ABIDE BY THE FOLLOWING CONDITIONS. INFORMATION CONTAINED IN PART OR IN WHOLE REMAINS WITH DODSON MOTORSPORT. DODSON MOTORSPORT ACCEPTS NO RESPONSIBILITY FOR ANY REASON WHATSOEVER. DO NOT COPY / REPRODUCE IN ANY FORM OR MAKE PUBLIC WITHOUT THE PERMISSION OF DODSON MOTORSPORT.

STEP 5

Remove the **clutch stacks**. This can be done by flipping the whole assembly.

Be careful not to damage the sealing rings on the underside of the clutch core.



BY OPENING AND USING THIS DOCUMENT YOU AGREE TO ABIDE BY THE FOLLOWING CONDITIONS. INFORMATION CONTAINED IN PART OR IN WHOLE REMAINS WITH DODSON MOTORSPORT. DODSON MOTORSPORT ACCEPTS NO RESPONSIBILITY FOR ANY REASON WHATSOEVER. DO NOT COPY / REPRODUCE IN ANY FORM OR MAKE PUBLIC WITHOUT THE PERMISSION OF DODSON MOTORSPORT.

ASSEMBLY

STEP 1

Start the assembly by installing the clutch stacks. These should be installed in the same order as supplied.

Note: The frictions have a specific direction, ensure the friction grooves have the same orientation as the photo when installed.



STEP 2

For easier installation, fit the **OE small basket** and then insert the **small clutch stack** one by one.



STEP 3

Please keep the **cut-outs on the steel plates** inline with each other while installing the plates into the core.



BY OPENING AND USING THIS DOCUMENT YOU AGREE TO ABIDE BY THE FOLLOWING CONDITIONS. INFORMATION CONTAINED IN PART OR IN WHOLE REMAINS WITH DODSON MOTORSPORT. DODSON MOTORSPORT ACCEPTS NO RESPONSIBILITY FOR ANY REASON WHATSOEVER. DO NOT COPY / REPRODUCE IN ANY FORM OR MAKE PUBLIC WITHOUT THE PERMISSION OF DODSON MOTORSPORT.

STEP 4

Finish off the small clutch stack with the OE top plate and fit the small clutch circlip.



STEP 5

Check the **clearance** of the small clutch by measuring the distance between the top plate and the bottom of the circlip.

This value should be 1.8 +/- 0.2mm.

If reaching this clearance is not possible, please contact us at technical@dodsonmotorsport.com

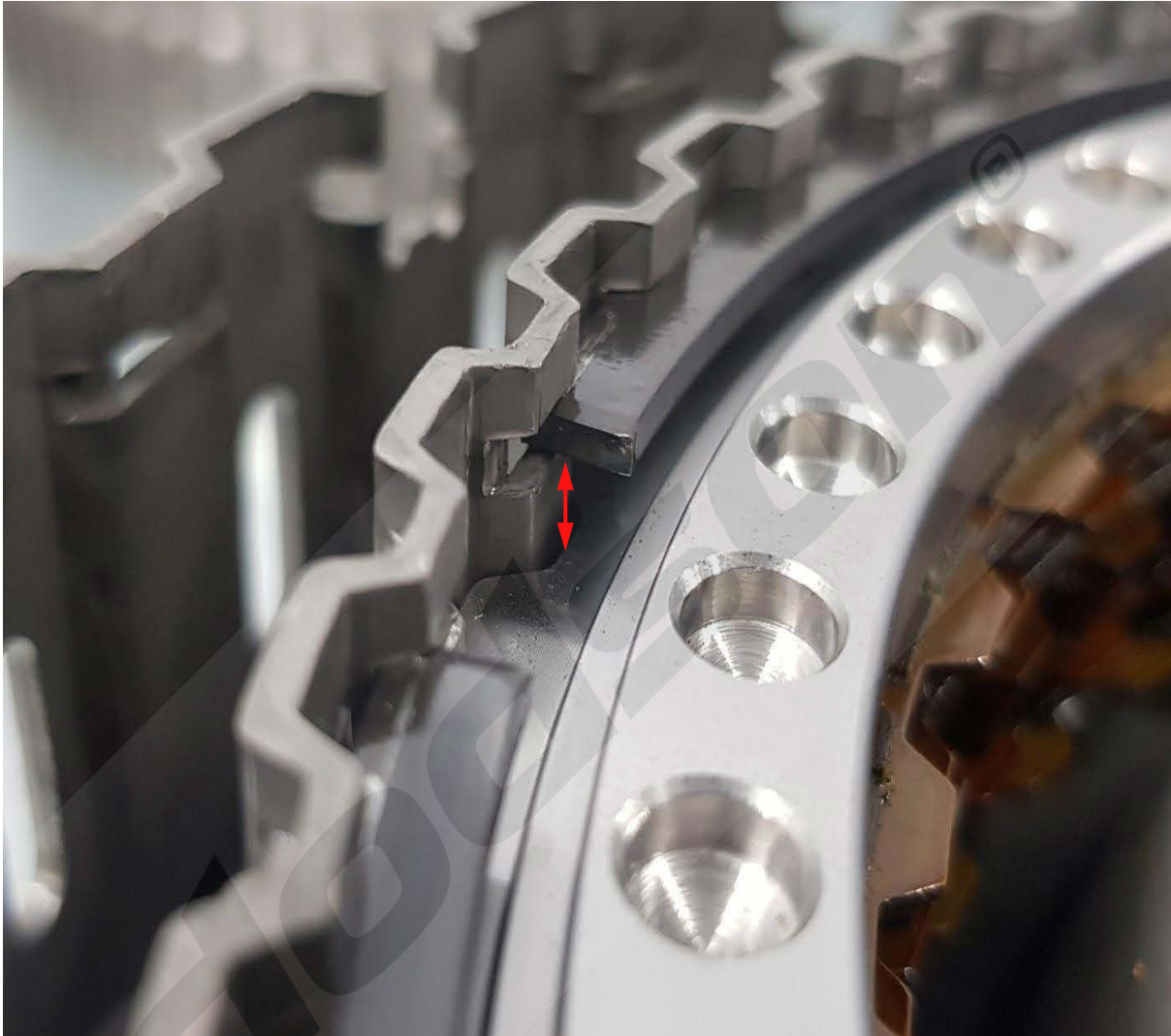

STEP 6

Ensure both **thrust bearings** on the large basket are in good condition fitted correctly.
Fit the **large basket**.



STEP 7

Install the **large clutch stack**.

Note the correct orientation of the friction plates as indicated in Step 1.



BY OPENING AND USING THIS DOCUMENT YOU AGREE TO ABIDE BY THE FOLLOWING CONDITIONS. INFORMATION CONTAINED IN PART OR IN WHOLE REMAINS WITH DODSON MOTORSPORT. DODSON MOTORSPORT ACCEPTS NO RESPONSIBILITY FOR ANY REASON WHATSOEVER. DO NOT COPY / REPRODUCE IN ANY FORM OR MAKE PUBLIC WITHOUT THE PERMISSION OF DODSON MOTORSPORT.

STEP 8

Once again, keep the **cut-outs in the steel plates** inline with each other while installing the plates.



STEP 9

Temporarily fit the **clutch lid**. Make sure to line up the marks made during disassembly.



STEP 10

Fit the **clutch lid circlip**.



STEP 11

Check the **clearance of the large clutch** by measuring in through the oiling holes on the exterior of the clutch core (**the clutch lid and circlip have to be installed**).

Take the measurement between **2 x steel plates** and subtract **1.35mm** (the thickness of the friction).

This value should be 1.9 +/- 0.2mm.

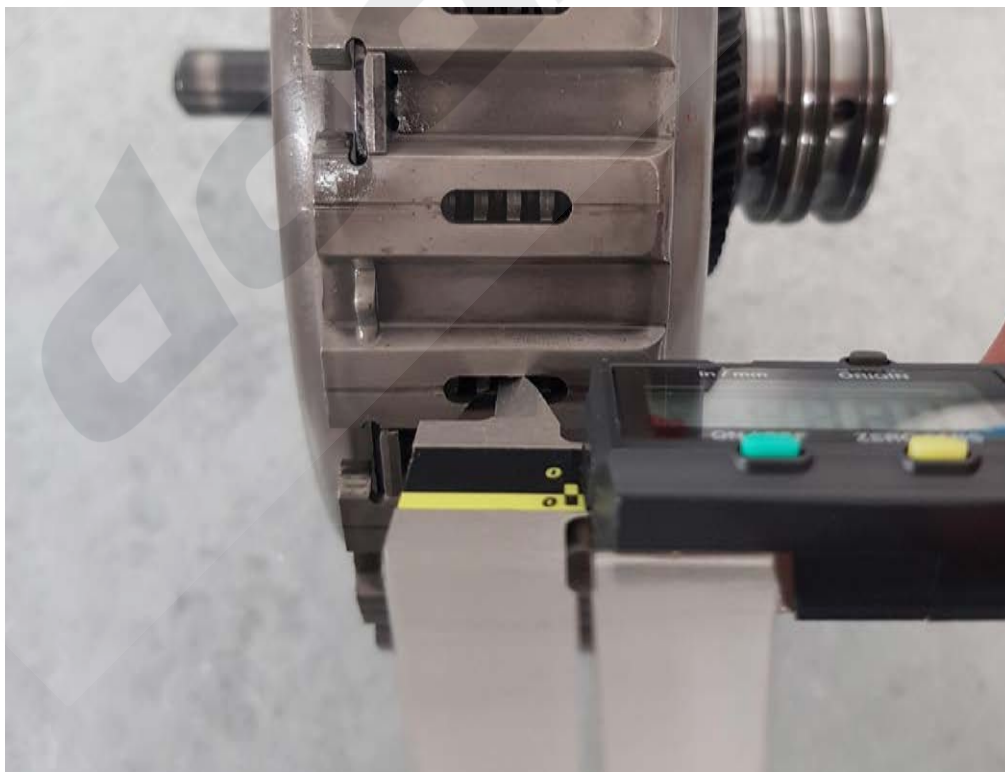

BY OPENING AND USING THIS DOCUMENT YOU AGREE TO ABIDE BY THE FOLLOWING CONDITIONS. INFORMATION CONTAINED IN PART OR IN WHOLE REMAINS WITH DODSON MOTORSPORT. DODSON MOTORSPORT ACCEPTS NO RESPONSIBILITY FOR ANY REASON WHATSOEVER. DO NOT COPY / REPRODUCE IN ANY FORM OR MAKE PUBLIC WITHOUT THE PERMISSION OF DODSON MOTORSPORT.

STEP 12

The clutch unit is ready to be reassembled into the transmission.



STEP 13

Once in the transmission, **remove the clutch lid again to install the circlip holding the large basket.** (the core may drop down a little further)

Re-fit the **clutch lid and circlip**. Help from a second technician may be required to lift the core slightly to allow for the circlip to be installed.

Please avoid turning the clutch during this procedure to make sure the friction plates do not fall out of alignment with the basket.

Fit the clutch cover - **ensure the seal is not damaged during reassembly**. Once seated correctly fit the OE clutch cover circlip.

IMPORTANT NOTE

PLEASE MAKE SURE THAT THE BASIC SETTING AND ADAPTION DRIVE PROCEDURES ARE SUCCESSFULLY COMPLETED BEFORE USING THE FULL POWER OF THE VEHICLE.

If you have any questions email us at technical@dodsonmotorsport.com

BY OPENING AND USING THIS DOCUMENT YOU AGREE TO ABIDE BY THE FOLLOWING CONDITIONS. INFORMATION CONTAINED IN PART OR IN WHOLE REMAINS WITH DODSON MOTORSPORT. DODSON MOTORSPORT ACCEPTS NO RESPONSIBILITY FOR ANY REASON WHATSOEVER. DO NOT COPY / REPRODUCE IN ANY FORM OR MAKE PUBLIC WITHOUT THE PERMISSION OF DODSON MOTORSPORT.