

dodson[®]

INSTALLATION INSTRUCTIONS

BMW SUPERSTOCK 8 CLUTCH

DMS-00-0027 REV 004

24 JANUARY 2024

**PREPARED BY: JAN PISL
DATE: 16JAN2024**

**RELEASED BY:
DATE: 24JAN2024**

REVISION UPDATE NOTES:

The following table indicates the changes we have made in either the disassembly or assembly of the product you have received. All changes are indicated by a revision bar in the margin.

If you have any questions email us at technical@dodsonmotorsport.com

| Revision | Date | Description |
|-------------|-----------|--|
| REV.004 | 24JAN2024 | <ul style="list-style-type: none">- Updated contents list, photos and related instruction steps to suit Gen 2.- Page 2: Added References.- Page 4: Added TCM tune info.- Moved the “Clutch Calibration” section to a separate document with a reference (DMS-00-0069).- Page 10: Added directionality instructions for clutch plates |
| REV.001-003 | | <ul style="list-style-type: none">- Archived |

NOTE

- This kit requires the reuse of the OE circlips and clutch kit top plates.
- The frictions have a specific direction, ensure the friction grooves have the same orientation as the photo when installed. See Page 10.



REFERENCES

- [DMS-00-0029](#) - BMW Clutch Clearance Measurement Instructions
- [DMS-00-0069](#) - BMW ISTA+ Clutch Calibration Instructions

BY OPENING AND USING THIS DOCUMENT YOU AGREE TO ABIDE BY THE FOLLOWING CONDITIONS. INFORMATION CONTAINED IN PART OR IN WHOLE REMAINS WITH DODSON MOTORSPORT. DODSON MOTORSPORT ACCEPTS NO RESPONSIBILITY FOR ANY REASON WHATSOEVER. DO NOT COPY / REPRODUCE IN ANY FORM OR MAKE PUBLIC WITHOUT THE PERMISSION OF DODSON MOTORSPORT.

BMW SUPERSTOCK 8 CONTENTS (DMS-8004)

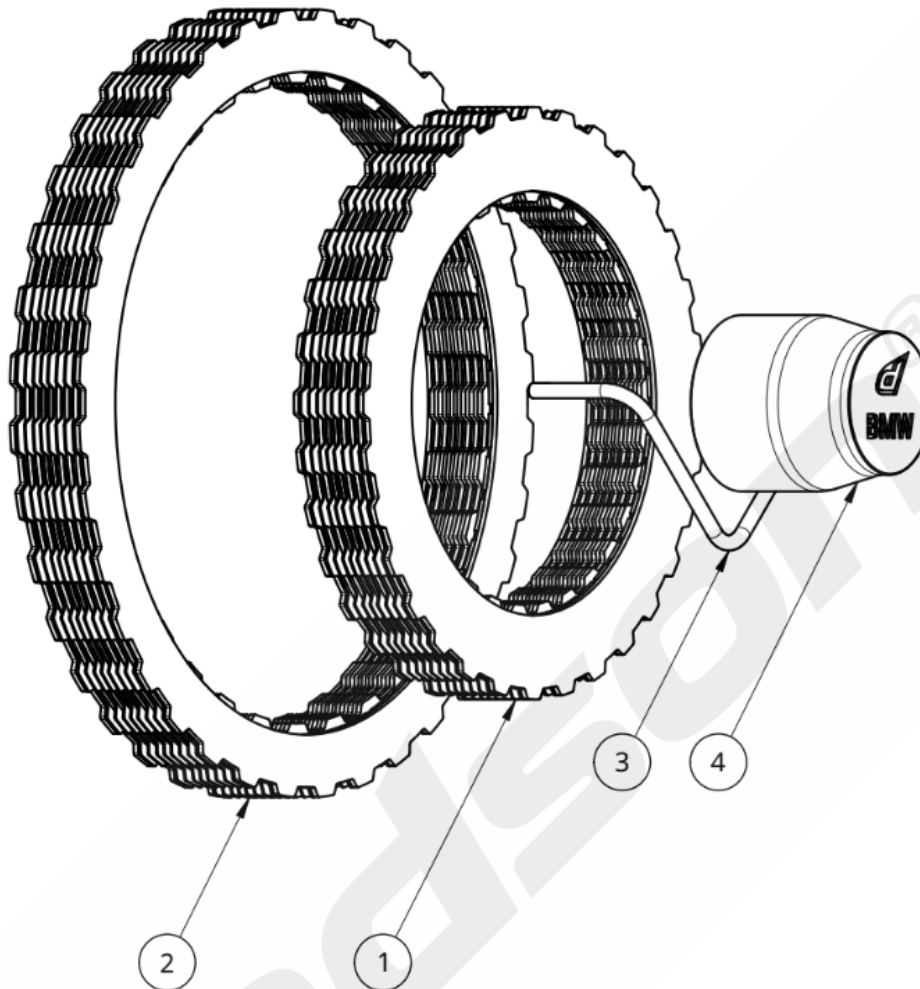

| Item Number | Part Name | DMS Code | Qty |
|-------------|---------------------|----------|-----|
| 1 | Small Clutch Stack | DMS-2565 | 1 |
| 2 | Large Clutch Stack | DMS-2566 | 1 |
| 3 | Clutch Removal Tool | DMS-2300 | 1 |
| 4 | Seal Guide | DMS-2301 | 1 |

READ FIRST - THESE INSTRUCTIONS MUST BE FOLLOWED EXACTLY

A TRANSMISSION TUNE IS REQUIRED TO PREVENT DAMAGE TO THE CLUTCH AND TO GET THE BEST BENEFITS FROM IT.

We have seen great results when using the **OEM BMW M4 GTS** transmission tune, however, if an aftermarket tune is more desirable, the important aspects that need to be considered are:

- Increasing clutch pressure to ensure that the clutch is fully clamped when power is applied.
- Modifying the torque tables, as a modified car will be applying far more torque at lower RPM than the TCU is tuned for. The TCU also intentionally slips the clutch at low RPM for a more comfortable drive, but with engine and transmission modifications, this can burn the clutch.
- Since the "comfort mode" allows the clutch to slip, it is important to make sure this isn't a default setting on start up if possible.
- Moving the shift points so the car doesn't hold 2nd gear at low RPM (or even at a stop). Heavy torque applied in 2nd gear at low RPM can burn the small stack.
- Not every off-the-shelf transmission tune will resolve this, and so it's important that the aspects mentioned above have been considered and that they have been discussed with your tuner.

THE 3 POSITION SWITCH AS SEEN BELOW SHOULD BE IN MODE 3 FOR DRAG RACING. FOR HIGH HORSEPOWER CARS, IT SHOULD BE IN MODE 2 OR 3.



WE RECOMMEND ALWAYS USING MODE 2 AT A MINIMUM.

New fluid and filters must be used when installing a Dodson clutch. Once the clutch is installed and the calibration is successful, it is strongly recommended to drive ~10km and then perform the clutch calibration a second time.

After this, it is recommended to perform the next 50-100km in the following driving conditions: Split the distance into several trips. Do not constantly use light throttle. Do not use full power during this drive. A moderate amount of throttle is recommended. This procedure will allow the clutch to properly bed in and then automatically adjust to the conditions.

Disabling the traction control system or engaging the launch control system will accelerate wear or potentially damage the clutch and transmission. These functions are to be altered at the user's own risk.

BMW SUPERSTOCK 8 INSTALLATION INSTRUCTIONS

CLUTCH REMOVAL

STEP 1

Angle transmission on table to prevent fluid loss.

(If you have drained the transmission then this is not necessary)



STEP 2

Remove the **circlip** from the clutch cover. It will be re-used when re-assembling the clutch.



STEP 3

Thread **three suitable M5 bolts** into the clutch cover and use them to gently pry it out of the transmission. Alternatively a small sliding hammer with a suitable attachment can be used.

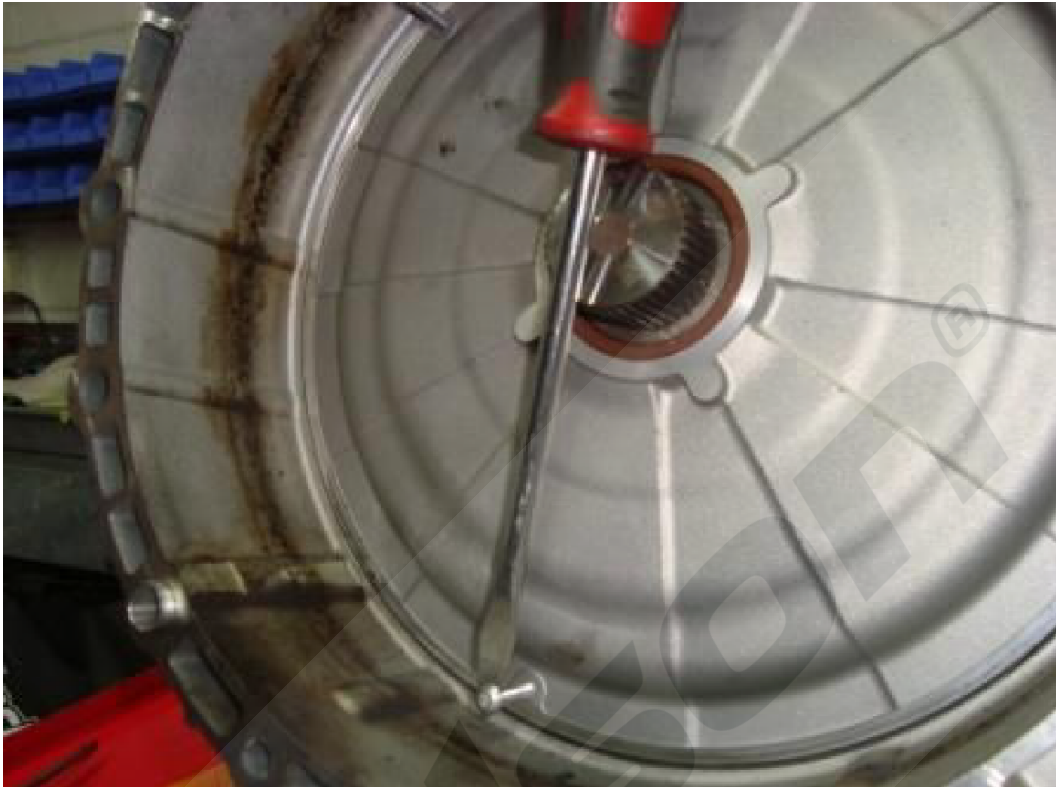

STEP 4

Remove clutch cover, **being careful of the center seal.**



STEP 5

Insert the **Clutch Removal Tool (DMS-2300)** into the clutch unit until flush with the lid.



STEP 6

While holding the **park lever** open, spin the clutch unit anti-clockwise to loosen the lock nut. Then carefully remove the clutch from transmission.



CLUTCH DISASSEMBLY

STEP 1

Mark the outer cage in respect to the clutch lid to maintain correct orientation when reassembling. Remove the outer circlip.



STEP 2

Remove the clutch lid, exposing both clutch baskets and clutches.



STEP 3

Remove both large and small clutch baskets.

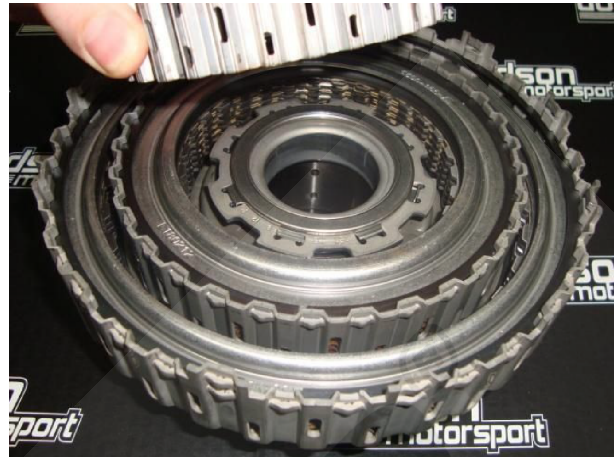

STEP 4

Remove both large and small circlips.



STEP 5

Carefully flip the clutch core upside down to remove all frictions/steels.



BY OPENING AND USING THIS DOCUMENT YOU AGREE TO ABIDE BY THE FOLLOWING CONDITIONS. INFORMATION CONTAINED IN PART OR IN WHOLE REMAINS WITH DODSON MOTORSPORT. DODSON MOTORSPORT ACCEPTS NO RESPONSIBILITY FOR ANY REASON WHATSOEVER. DO NOT COPY / REPRODUCE IN ANY FORM OR MAKE PUBLIC WITHOUT THE PERMISSION OF DODSON MOTORSPORT.

CLUTCH ASSEMBLY

IMPORTANT NOTE

The frictions have a specific direction, ensure the friction grooves have the same orientation as the photo when installed. SOAK THE FRICTIONS IN TRANSMISSION FLUID BEFORE FINAL INSTAL.

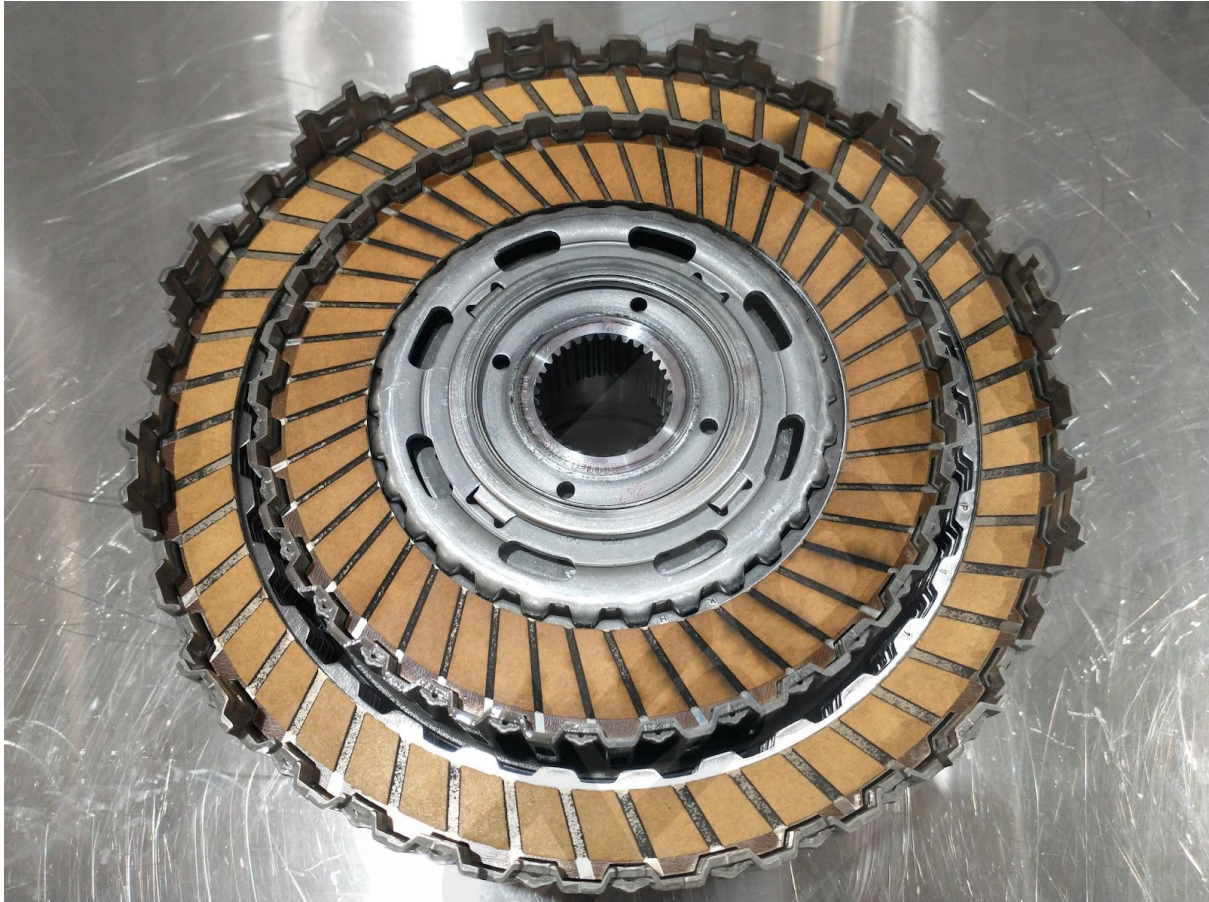

STEP 1

Ensure the **clutch lock nut** thread and thrust bearings (one on each side) are in good condition and correctly located then place it in the clutch core with the thread facing down.



STEP 2

Fit the **small basket** to help with assembly of the small stack. Ensure the thrust bearing is in good condition and correctly seated on top of the basket.

The stack should be installed in the same order as supplied. Starting with the end plate (same profile as the friction plates), followed by a friction, steel plate etc. ending with an end plate again.



STEP 3

Fit the **OE top plate and circlip** to finish off the small stack.

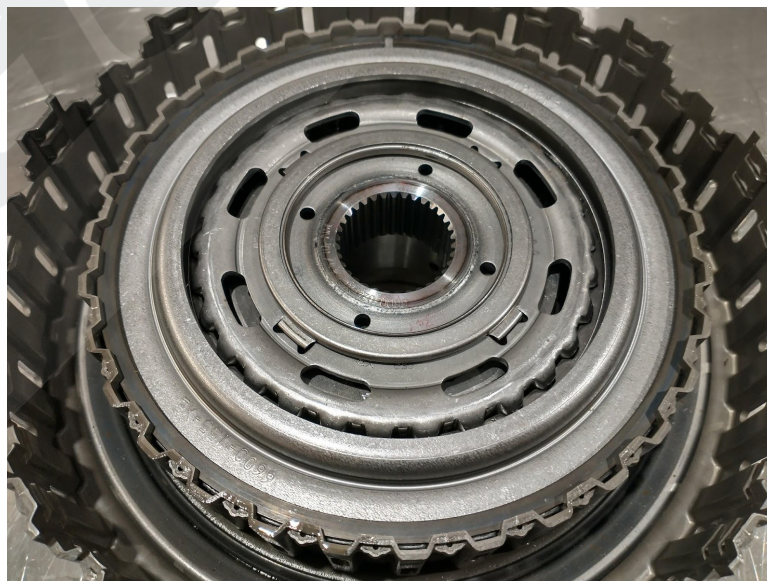

NOTE

Now would be a good time to check the small stack clearance.
Please follow the **Dodson BMW Clutch Clearance Measurement Instructions (DMS-00-0029)**.

THE CLEARANCE SHOULD BE: 2.60 +/- 0.20mm

If reaching this clearance is not possible, please contact us at technical@dodsonmotorsport.com
(Dodson has range of circlips available)

STEP 4

Fit the **large basket** to help with assembly of the large stack. Ensure the thrust bearing is in good condition and correctly seated on top of the basket.

The stack should be installed in the same order as supplied. Starting with the end plate (same profile as the friction plates), followed by a friction, steel plate etc. ending with an end plate again.



STEP 5

Fit the OE top plate and circlip to finish off the large stack.



NOTE

Now would be a good time to check the small stack clearance.
Please follow the **Dodson BMW Clutch Clearance Measurement instructions (DMS-00-0029)**.

THE CLEARANCE SHOULD BE: 2.60 +/- 0.20mm

If reaching this clearance is not possible, please contact us at technical@dodsonmotorsport.com
(Dodson has range of circlips available)

STEP 6

Reinstall the **clutch lid** ensuring marks made during disassembly are lined up.
Fit the **OE lid circlip** and make sure it is tight.



BY OPENING AND USING THIS DOCUMENT YOU AGREE TO ABIDE BY THE FOLLOWING CONDITIONS. INFORMATION CONTAINED IN PART OR IN WHOLE REMAINS WITH DODSON MOTORSPORT. DODSON MOTORSPORT ACCEPTS NO RESPONSIBILITY FOR ANY REASON WHATSOEVER. DO NOT COPY / REPRODUCE IN ANY FORM OR MAKE PUBLIC WITHOUT THE PERMISSION OF DODSON MOTORSPORT.

CLUTCH INSTALLATION

STEP 1

Fit the clutch unit into the transmission with the **Clutch Removal Tool (DMS-2300)** inserted.



STEP 2

While holding the **park lever** open, spin the clutch unit clockwise to allow the basket splines to line up, and then keep turning clockwise until the lock nut is all the way home and nipped-up. Then remove the clutch tool.



BY OPENING AND USING THIS DOCUMENT YOU AGREE TO ABIDE BY THE FOLLOWING CONDITIONS. INFORMATION CONTAINED IN PART OR IN WHOLE REMAINS WITH DODSON MOTORSPORT. DODSON MOTORSPORT ACCEPTS NO RESPONSIBILITY FOR ANY REASON WHATSOEVER. DO NOT COPY / REPRODUCE IN ANY FORM OR MAKE PUBLIC WITHOUT THE PERMISSION OF DODSON MOTORSPORT.

STEP 3

Fit the **seal guide** and then carefully fit the clutch cover over it.



STEP 4

Ensure the arrow on the cover is pointing upwards.



STEP 5

Using a soft hammer, gently tap the clutch cover until it is fully home.



STEP 6

Refit the clutch cover circlip.



IMPORTANT NOTE

PLEASE MAKE SURE THAT THE TRANSMISSION FLUID FILLING PROCEDURE IS COMPLETED AS PER MANUFACTURER SPECIFICATION AND THAT THE CLUTCH CALIBRATION AND ROAD TEST PROCEDURES ARE SUCCESSFULLY COMPLETED AS PER DODSON CLUTCH CALIBRATION INSTRUCTIONS (DMS-00-0069) BEFORE USING THE FULL POWER OF THE VEHICLE.

If you have any questions email us at technical@dodsonmotorsport.com