

# ***dodson***<sup>®</sup>

## **INSTALLATION INSTRUCTIONS**

**DQ250 SPORTSMAN'S CLUTCH**

**DMS-00-0066 REV 003**

**10 JULY 2023**

**PREPARED BY: GREG BUCHANAN  
DATE: 19JUN2023**

**RELEASED BY: J.PISL  
DATE: 10JUL2023**

*AFD*

## REVISION UPDATE NOTES:

The following table indicates the changes made in this document since the previous revision. All changes will be indicated by a revision bar in the margin.

If you have any questions email us at [technical@dodsonmotorsport.com](mailto:technical@dodsonmotorsport.com)

Revision	Date	Description
REV.003	10JUL2023	- Added Trans tune recommendation.
REV.002	03MAY2023	- Updated to new format - Modified assembly instructions for clarity.
REV.001	14SEP2021	- Updated to new format and updated the BOM table

## READ FIRST

### **A TRANSMISSION TUNE IS RECOMMENDED TO PREVENT DAMAGE TO THE CLUTCH AND TO GET THE BEST BENEFITS FROM IT.**

We have seen great results when using our clutch kits with a suitable transmission tune. When choosing an aftermarket tune, the important aspects that need to be considered are:

- Increasing clutch pressure to ensure that the clutch is fully clamped when power is applied.
- Modifying the torque tables, as a modified car will be applying far more torque at lower RPM than the TCU is tuned for. The TCU may also intentionally slip the clutch at low RPM for a more comfortable drive, but with engine and transmission modifications, this can burn the clutch.
- Since the "comfort mode" allows the clutch to slip, it is important to make sure this isn't a default setting on start up, if possible.
- Moving the shift points so the car doesn't hold 2nd gear at low RPM (or even at a stop). Heavy torque applied in 2nd gear at low RPM can burn the small stack.
- Not every off-the-shelf transmission tune will resolve this, and so it's important that the aspects mentioned above have been considered and that they have been discussed with your tuner.

For best results, we recommend only using **Manual (M)** or **Sport (S)** transmission modes. In some cases manually shifting into 1st gear before coming to a stop may be required to prevent "bumping". (which can be caused by the larger clutch and its increased coefficient of friction)

## DQ250 SPORTSMAN'S CLUTCH KIT CONTENTS (DMS-8053)

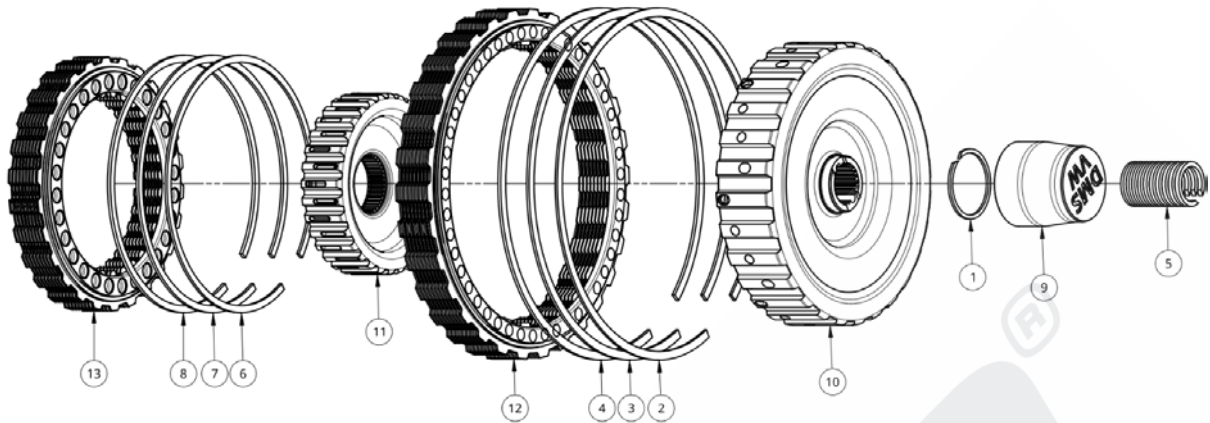

Item Number	Part Name	DMS Code	Qty
1	Small Basket Snap Ring	DMS-0900	1
2	Large Circlip - 1.5mm	DMS-0982	1
3	Large Circlip - 1.7mm	DMS-0983	1
4	Large Circlip - 1.9mm	DMS-0984	1
5	OEM Circlip Kit (1.8mm - 2.7mm)	DMS-0988	1
6	Small Circlip - 1.6mm	DMS-0990	1
7	Small Circlip - 1.8mm	DMS-0991	1
8	Small Circlip - 2.0mm	DMS-0992	1
9	Clutch Cover Seal Guide	DMS-2409	1
10	Large Clutch Basket	DMS-3224	1
11	Small Clutch Basket	DMS-3225	1
12	Large Clutch Stack	DMS-8175	1
13	Small Clutch Stack	DMS-8176	1

BY OPENING AND USING THIS DOCUMENT YOU AGREE TO ABIDE BY THE FOLLOWING CONDITIONS. INFORMATION CONTAINED IN PART OR IN WHOLE REMAINS WITH DODSON MOTORSPORT. DODSON MOTORSPORT ACCEPTS NO RESPONSIBILITY FOR ANY REASON WHATSOEVER. DO NOT COPY / REPRODUCE IN ANY FORM OR MAKE PUBLIC WITHOUT THE PERMISSION OF DODSON MOTORSPORT.

## **DQ250 SPORTSMAN'S CLUTCH KIT INSTRUCTIONS**

### **DISASSEMBLY**

#### **STEP 1**

Turn the gearbox on its end so that the clutch cover is facing up. Remember to either have the oil drained first or block off the breather so it doesn't spill out. Remove the large clutch cover circlip.



#### **STEP 2**

Remove the clutch cover, being careful not to damage the inner lip seal. Do not touch the seal with your fingers.



## **STEP 3**

Remove circlip and mark position as shown in the diagram. Remove the drive plate and set aside.

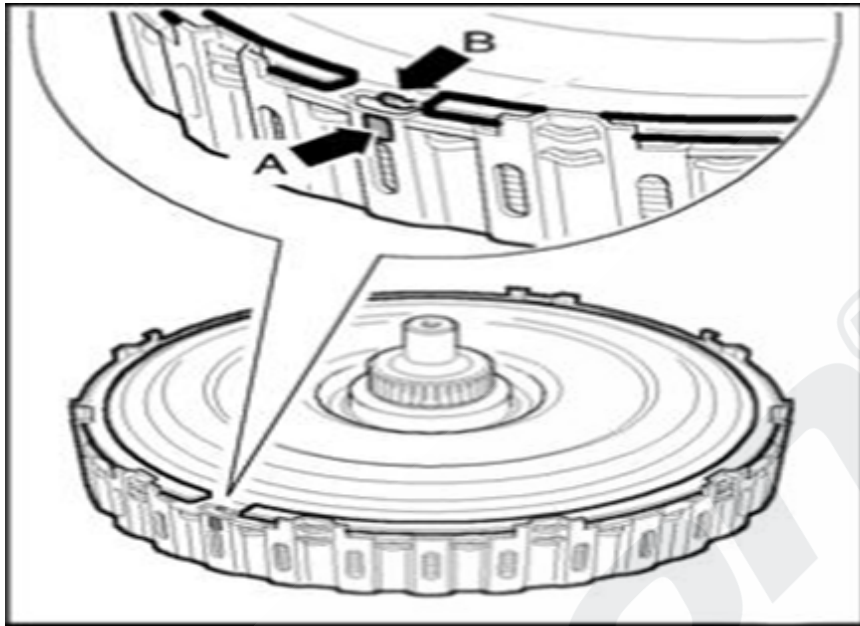

## **STEP 4**

Remove the clutch retaining circlip from the center.





## **STEP 5**

Hold the clutch unit firmly and lift it straight upwards. When setting the clutch unit down be careful of the seals on the underside of the clutch core. These can damage easily if dropped.



## **STEP 6**

Remove the oil pump drive shaft.



## **STEP 7**

Remove Large and Small baskets.

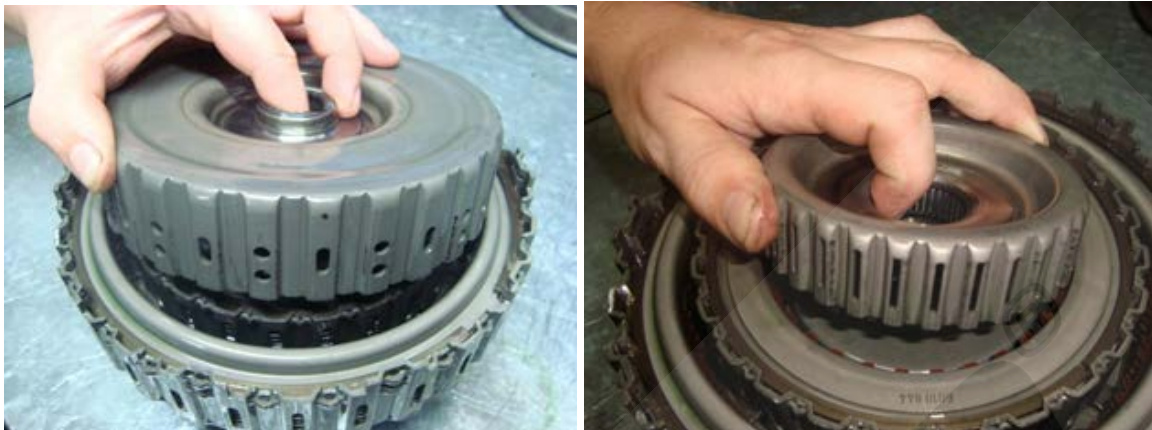

## **STEP 8**

Remove Small and Large circlips.



## **STEP 9**

Carefully flip the entire assembly upside down to tip out all of the frictions and steels.



## **ASSEMBLY**

### **STEP 1**

Start the assembly by installing the clutch stacks. These should be installed in the same order as supplied. Installing the baskets may help with lining up the friction teeth.

**Note: The frictions have a specific direction, ensure the friction grooves have the same orientation as the photo when installed. SOAK THE FRICTIONS IN TRANSMISSION FLUID BEFORE FINAL INSTAL.**



### **STEP 2**

Fit both top plates.



BY OPENING AND USING THIS DOCUMENT YOU AGREE TO ABIDE BY THE FOLLOWING CONDITIONS. INFORMATION CONTAINED IN PART OR IN WHOLE REMAINS WITH DODSON MOTORSPORT. DODSON MOTORSPORT ACCEPTS NO RESPONSIBILITY FOR ANY REASON WHATSOEVER. DO NOT COPY / REPRODUCE IN ANY FORM OR MAKE PUBLIC WITHOUT THE PERMISSION OF DODSON MOTORSPORT.



## STEP 3

When assembling this clutch, our desired clearance is **3.0mm +/- 0.2mm**. The clearance can be altered by changing the circlips with the range provided with the clutch kit.

Clearance can be measured on both clutches using the height gauge end of vernier calipers by zeroing the calipers at the height between the top plate and the clutch core and then lifting the top plate all the way up against the circlip using a small flat head screwdriver or a pick as shown below.



## STEP 4

Refit both baskets to the clutch.

**Remember to transfer the bearing over from the large basket.**



## STEP 5

Place the Dodson or a VW clutch install tool into housing. Lower the clutch assembly into housing. **Do not drop into housing.** It is important to have a second technician hold the install tool in place as it can spin and let the clutch drop. If this happens you may have to disassemble the clutch and start again as the bottom friction can get misaligned from the basket.



## STEP 6

Refit the center circlip and the oil pump drive shaft.



**If a different clutch core is being used, please follow the "EXTRA STEPS" instructions on Page 12 before proceeding to STEP 7.**

## **STEP 7**

Reinstall the drive plate, aligning the marks. Fit the drive plate circlip.

You can now remove the clutch install tool.



## **STEP 8**

Fit the seal guide provided and fit the clutch cover while avoiding touching the center lip seal. It may be necessary to tap the cover with a soft hammer to get it fully seated.

Fit the large circlip.





## EXTRA STEPS

These instructions are only for fitting the clutch to a different or new gearbox. If you are installing the clutch to the same gearbox it came from, ignore these steps.

Fit a 2.0mm center circlip and follow the measurements and calculations below to determine the correct circlip thickness to achieve desired endfloat.

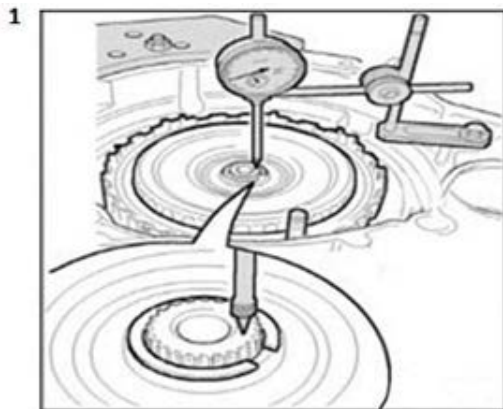

### First measurement:

**DMS VW Clutch Tool** remains installed!

Fit appropriate dial gauge

Place plunger of dial gauge on to transmission input shaft.

Set dial gauge to "0" with pre-load.

Lift clutch upward until it stops and note the measurement result.

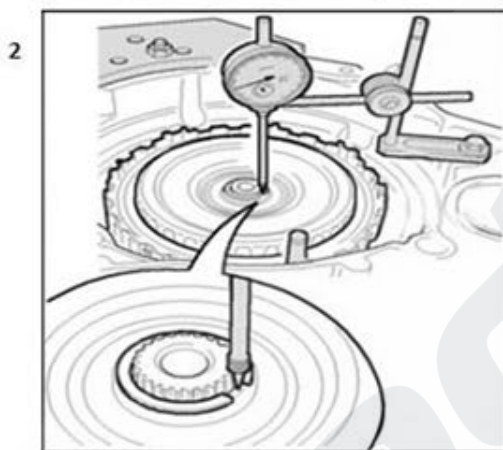

### Second measurement:

**DMS VW Clutch Tool** remains installed!

Place gauge plunger onto tab of large clutch pack carrier.

The plunger must not sit on the circlip.

Reset dial gauge to "0" with pre-load.

Lift clutch upward again to stop and note this result as well.

The calculation will be made to determine which of the remaining nine circlips will be finally installed:

- For this, use this formula:

Second measurement minus first measurement plus 1.85mm = thickness of circlip to be installed.

note this result.

The nine remaining securing circlips are stepped in 0.1mm increments.

Measure all circlips then determine the circlip which matches your result.

Remove the 2mm thick circlip & replace with the determined circlip.

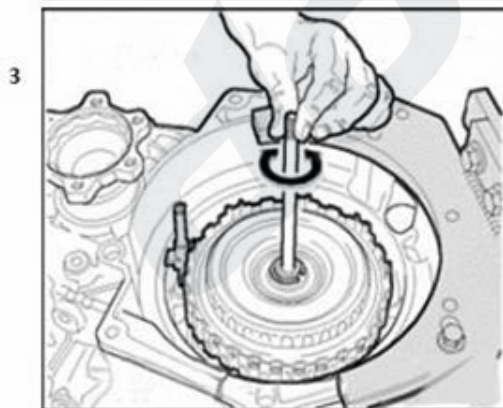

Install input shaft for transmission oil pump, turn slightly in direction of arrow - when doing this.

Once the correct circlip is fitted follow the rest of the assembly instructions from **Step 7**.



## **COMPLETED ASSEMBLY:**



## **IMPORTANT NOTES**

**PLEASE MAKE SURE THAT THE **BASIC SETTING AND ADAPTION DRIVE** PROCEDURES ARE SUCCESSFULLY COMPLETED BEFORE USING THE FULL POWER OF THE VEHICLE.**

**DODSON INSTRUCTIONS FOR THE PROCEDURE USING VCDS SOFTWARE ARE AVAILABLE IF NEEDED (DMS-00-0053).**

If you have any questions email us at [technical@dodsonmotorsport.com](mailto:technical@dodsonmotorsport.com)

BY OPENING AND USING THIS DOCUMENT YOU AGREE TO ABIDE BY THE FOLLOWING CONDITIONS. INFORMATION CONTAINED IN PART OR IN WHOLE REMAINS WITH DODSON MOTORSPORT. DODSON MOTORSPORT ACCEPTS NO RESPONSIBILITY FOR ANY REASON WHATSOEVER. DO NOT COPY / REPRODUCE IN ANY FORM OR MAKE PUBLIC WITHOUT THE PERMISSION OF DODSON MOTORSPORT.