

dodson[®]

**INSTALLATION
INSTRUCTIONS**

DQ381 SUPERSTOCK CLUTCH

DMS-00-0040 REV 002

10 JULY 2023

**PREPARED BY: GREG BUCHANAN
DATE: 19JUN2023**

**RELEASED BY: J.PISL
DATE: 10JUL2023**

AED

REVISION UPDATE NOTES:

The following table indicates the changes we have made in either the disassembly or assembly of the product you have received. All changes are indicated by a revision bar in the margin.

If you have any questions email us at technical@dodsonmotorsport.com

Revision	Date	Description
REV.002	10JUL2023	- Added Trans tune recommendation.
REV.001	24MAY2022	- Document creation.

READ FIRST

A TRANSMISSION TUNE IS RECOMMENDED TO PREVENT DAMAGE TO THE CLUTCH AND TO GET THE BEST BENEFITS FROM IT.

We have seen great results when using our clutch kits with a suitable transmission tune. When choosing an aftermarket tune, the important aspects that need to be considered are:

- Increasing clutch pressure to ensure that the clutch is fully clamped when power is applied.
- Modifying the torque tables, as a modified car will be applying far more torque at lower RPM than the TCU is tuned for. The TCU may also intentionally slip the clutch at low RPM for a more comfortable drive, but with engine and transmission modifications, this can burn the clutch.
- Since the "comfort mode" allows the clutch to slip, it is important to make sure this isn't a default setting on start up, if possible.
- Moving the shift points so the car doesn't hold 2nd gear at low RPM (or even at a stop). Heavy torque applied in 2nd gear at low RPM can burn the small stack.
- Not every off-the-shelf transmission tune will resolve this, and so it's important that the aspects mentioned above have been considered and that they have been discussed with your tuner.

For best results, we recommend only using **Manual (M)** or **Sport (S)** transmission modes. In some cases manually shifting into 1st gear before coming to a stop may be required to prevent "bumping". (which can be caused by the larger clutch and its increased coefficient of friction)

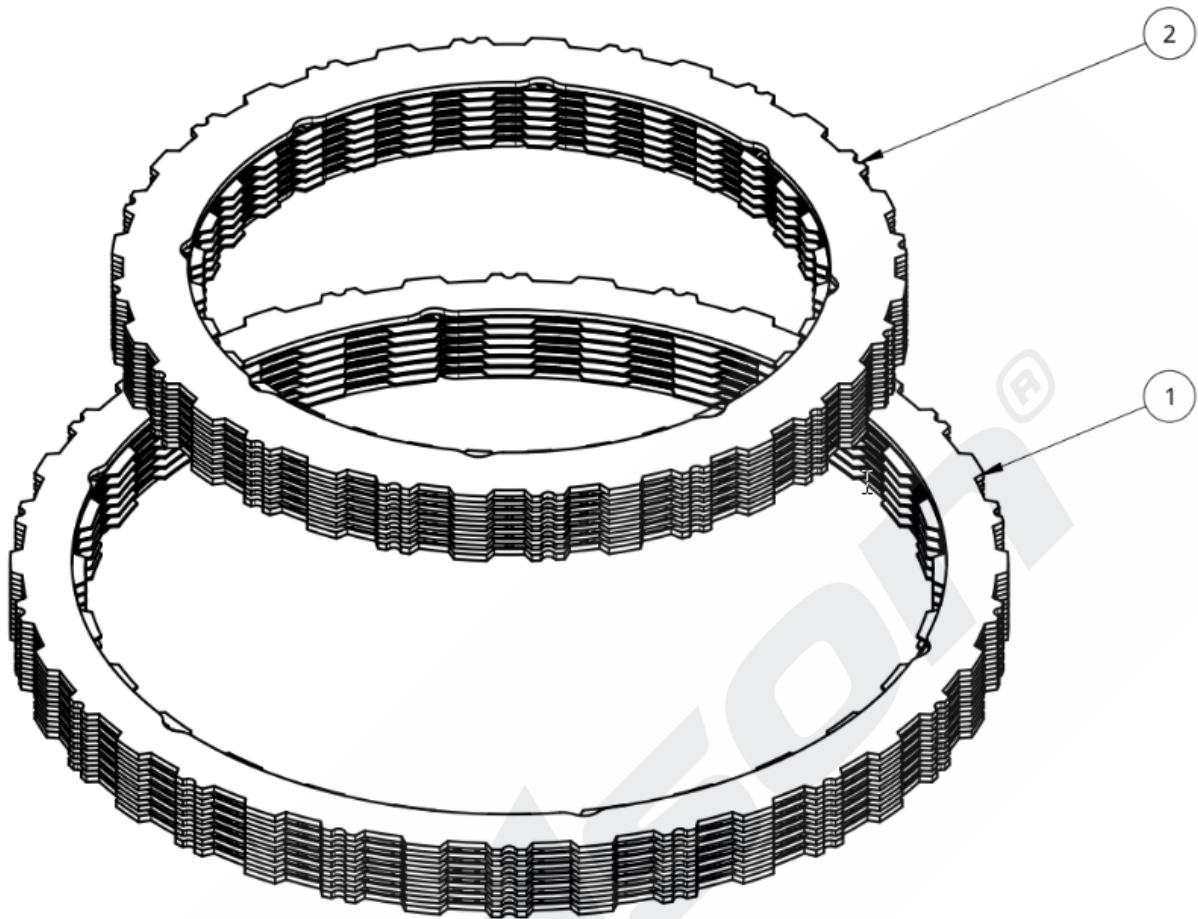
DQ381 SUPERSTOCK CLUTCH KIT CONTENTS (DMS-8075)

Item Number	Part Name	DMS Code	Qty
1	Large Clutch Stack	DMS-8145	1
2	Small Clutch Stack	DMS-8146	1

BY OPENING AND USING THIS DOCUMENT YOU AGREE TO ABIDE BY THE FOLLOWING CONDITIONS. INFORMATION CONTAINED IN PART OR IN WHOLE REMAINS WITH DODSON MOTORSPORT. DODSON MOTORSPORT ACCEPTS NO RESPONSIBILITY FOR ANY REASON WHATSOEVER. DO NOT COPY / REPRODUCE IN ANY FORM OR MAKE PUBLIC WITHOUT THE PERMISSION OF DODSON MOTORSPORT.

DQ381 SUPERSTOCK INSTALLATION INSTRUCTIONS DISASSEMBLY

STEP 1

To remove the clutch from the car you must remove the large circlip retaining the lid. You must then remove the lid and small circlip holding the large basket. **We recommend marking the lid to keep it in the same position during reassembly.**



STEP 2

Pull the clutch unit out of the transmission.



STEP 3

Remove both clutch baskets.



STEP 4

Remove the small clutch circlip using a small screwdriver or a pick.



STEP 5

Remove the clutch stacks. This can be done by flipping the whole assembly.

Be careful not to damage the sealing rings on the underside of the clutch core.



BY OPENING AND USING THIS DOCUMENT YOU AGREE TO ABIDE BY THE FOLLOWING CONDITIONS. INFORMATION CONTAINED IN PART OR IN WHOLE REMAINS WITH DODSON MOTORSPORT. DODSON MOTORSPORT ACCEPTS NO RESPONSIBILITY FOR ANY REASON WHATSOEVER. DO NOT COPY / REPRODUCE IN ANY FORM OR MAKE PUBLIC WITHOUT THE PERMISSION OF DODSON MOTORSPORT.

ASSEMBLY

STEP 1

Start the assembly by installing the clutch stacks. These should be installed in the same order as supplied.

Note: The frictions have a specific direction, ensure the friction grooves have the same orientation as the photo when installed.



STEP 2

For easier installation, fit the OE small basket and then insert the small clutch stack.



STEP 3

Please keep the cut-outs on the steel plates in line with each other while installing the plates into the core.

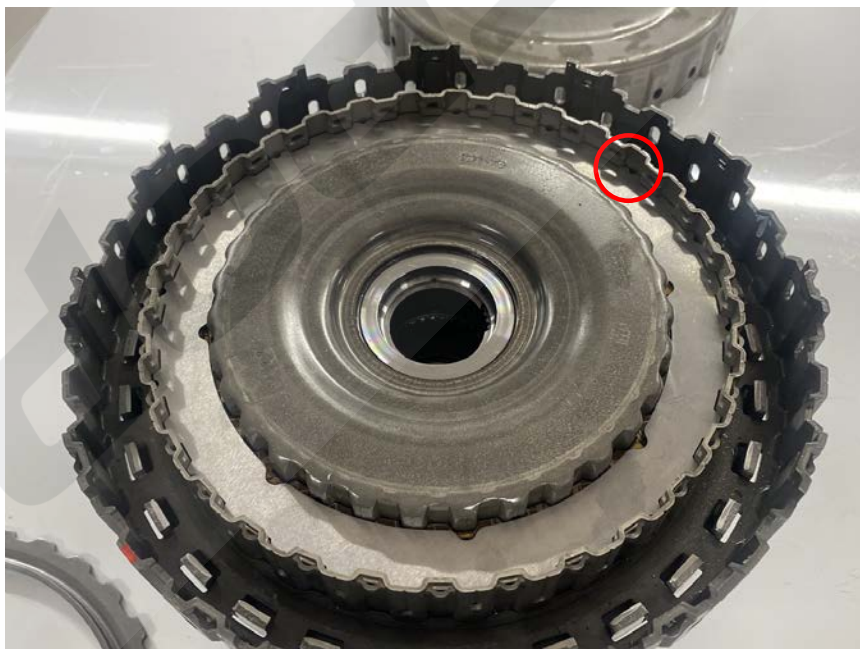

STEP 4

Finish off the small clutch stack with the OE top plate and fit the small clutch circlip.

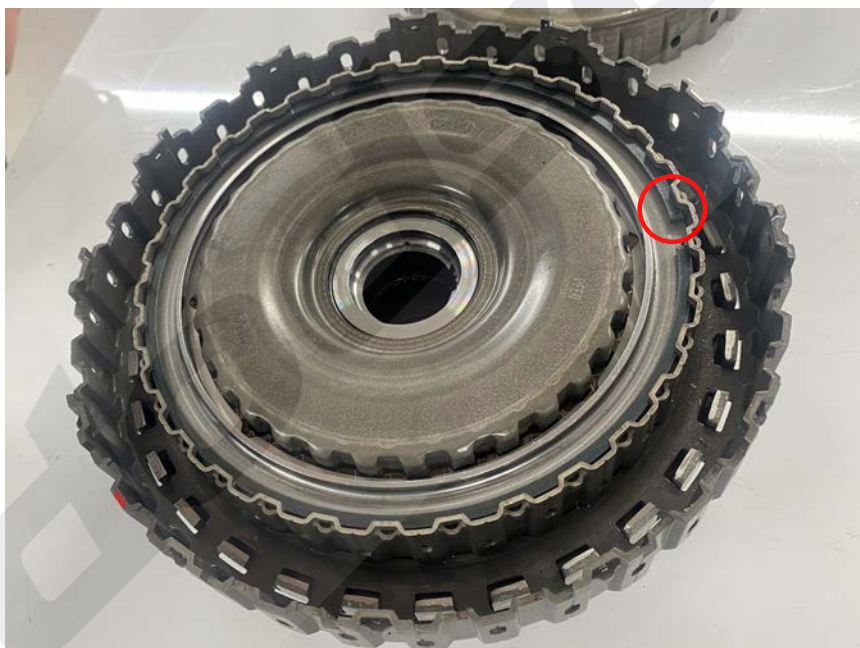

STEP 5

Check the clearance of the small clutch by measuring the distance between the top plate and the bottom of the circlip. **This value should be 1.8 +/- 0.2mm.**

If reaching this clearance is not possible, please contact us at technical@dodsonmotorsport.com

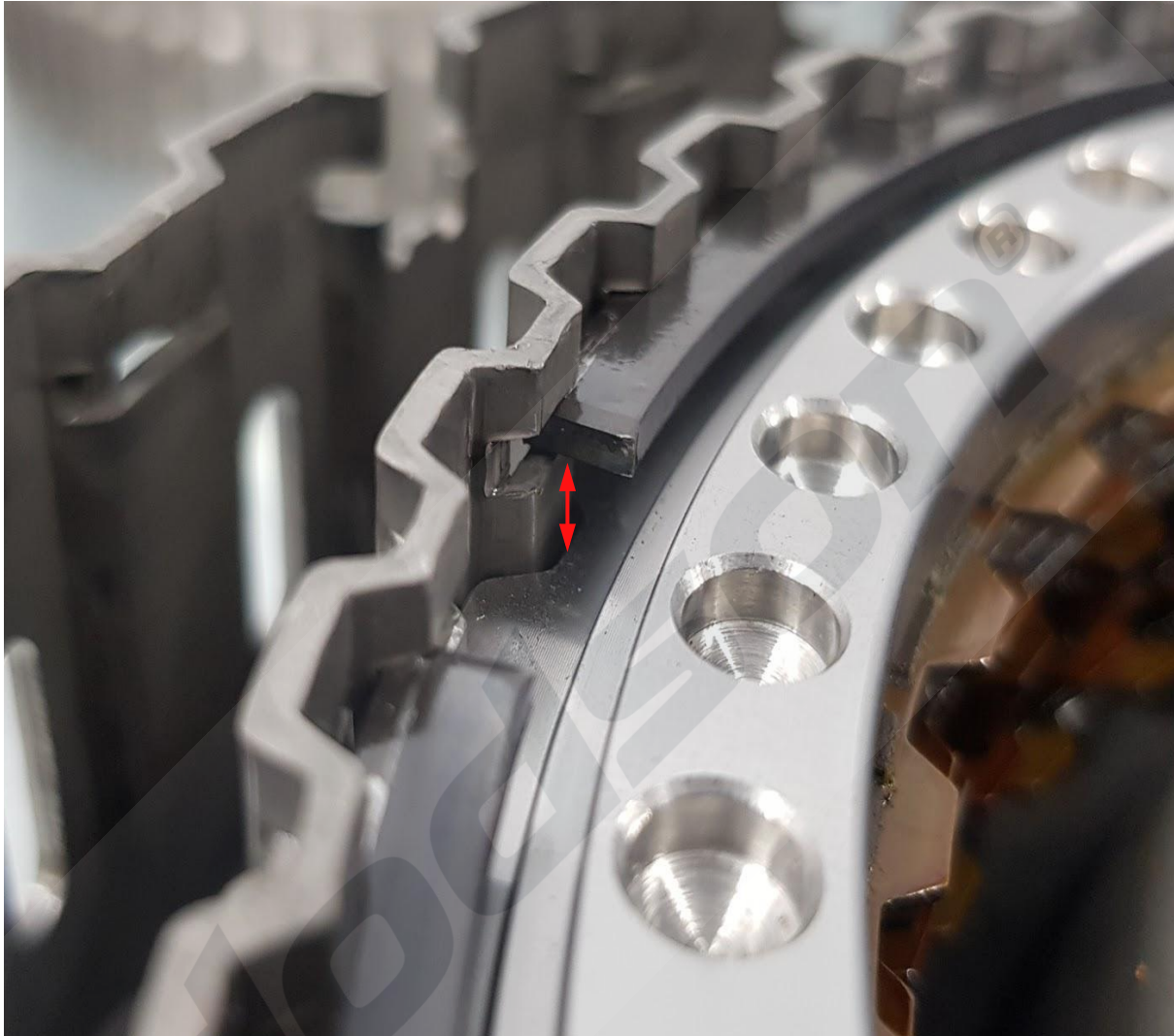

STEP 6

Fit the large basket.



STEP 7

Install the large clutch stack.

Note the correct orientation of the friction plates as indicated in step 1.



STEP 8

Once again, keep the cut-outs in the steel plates inline with each other while installing the plates.



STEP 9

Fit the clutch lid. Make sure to line up the marks made during disassembly.



STEP 10

Fit the clutch lid circlip.



STEP 11

Check the clearance of the large clutch by measuring in between the oiling holes on the exterior of the clutch core (the clutch lid and circlip have to be installed).

Take the measurement between 2 x steel plates and subtract 1.35mm (the thickness of the friction).

This value should be 2.2 +/- 0.2mm.

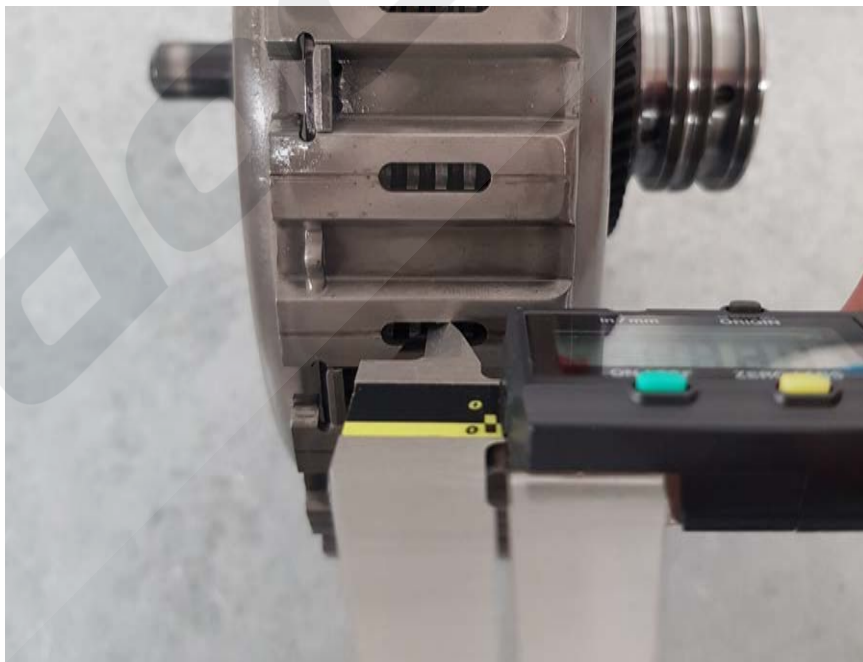

STEP 12

The clutch unit is ready to be reassembled into the transmission.



STEP 13

Once in the transmission, remove the clutch lid again to install the circlip holding the large basket. Re-fit the clutch lid and circlip, please make sure the friction plates do not fall out of alignment with the basket.

Fit the clutch cover - **it is helpful to use the provided Dodson seal guide**. Once seated correctly fit the OE clutch cover circlip.

IMPORTANT NOTE

PLEASE MAKE SURE THAT THE BASIC SETTING AND ADAPTION DRIVE PROCEDURES ARE SUCCESSFULLY COMPLETED BEFORE USING THE FULL POWER OF THE VEHICLE.

If you have any questions email us at technical@dodsonmotorsport.com